

POLARITY TESTER MODEL CMC 5687  
DESCRIPTION

**1. GENERAL**

1.01 The CMC 5687 Polarity Tester (Figure 1) is designed for checking polarity on any selector trunk capable of returning battery and ground from the succeeding switch. The schematic diagram is in Figure 2.

**2. DESCRIPTION**

2.01 The unit measures 3-11/16 x 1-11/16 x 1 1/2 inches overall, and weighs approximately 5 ounces. Housed in the acrylic case are 2 type 48B lamps, 2 lampholders, and 2 diodes. To the rear of the unit is a modified 240-A plug for insertion into the switch test jacks. On the bottom of the unit is a test jack for insertion of a hand test telephone (type 800 or similar).

2.02 The white and red lamp caps on the front of the unit indicate the polarity of the trunk being tested. When the white (STR) lamp lights dimly, the polarity is correct; that is, negative battery is present on the Ring (-) lead and positive ground is present on the Tip (+) lead.

When the red (REV) lamp lights dimly, the polarity is reversed.

2.03 An increased brilliancy in either lamp indicates a grounded Tip, battery crossed to Ring, or a double connected trunk.

2.04 The unit must be plugged into the switch test jacks as indicated by the arrows on the front of the unit, (Figure 1b).

2.05 The lamps are the only parts used in the unit that should ever require replacing. These must be replaced with type 48B lamps only.

2.06 Remove the lamp caps by using a lamp cap extractor (Klein 319-B or equivalent). A groove has been molded into the front of the acrylic case to allow insertion of the cap extractor.

2.07 Remove the lamp by using a lamp extractor (Neuses N-553-A or equivalent).

2.08 Refer to GSP Sections in the 226 series for tests using the CMC 5687 polarity tester.

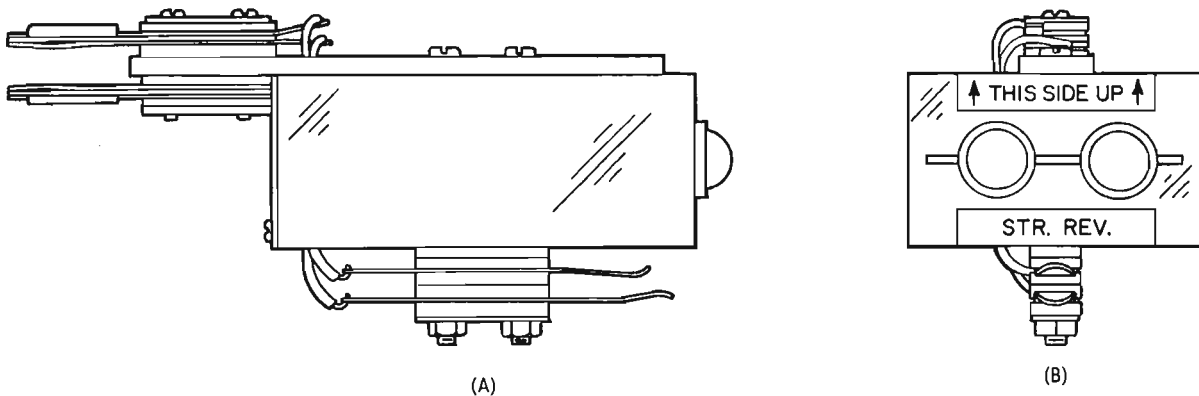

Figure 1. Model CMC 5687 Polarity Tester (a) Side View, (b) Front View

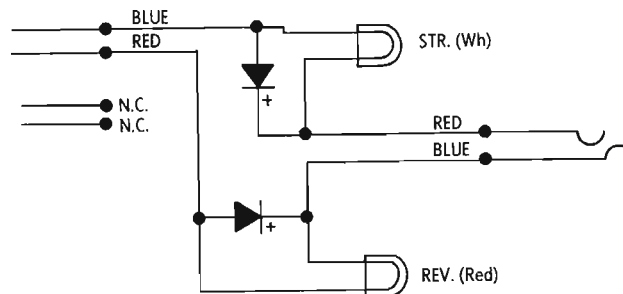

Figure 2. Schematic Diagram of Polarity Tester.