

2A TELEPHONE ANSWERING SET REQUIREMENTS AND ADJUSTMENTS

1.00 GENERAL

1.01 This section contains **REQUIREMENTS** (2.00) and **ADJUSTMENTS** (3.00) for 2A telephone answering sets. Lubrication is covered under Requirements.

1.02 The following components are covered:

- Operating controls
- Announcement-bail carriage and head
- Operating rods
- Drum clutch pressure
- Erase coil assembly
- Drum latch and motor control switch
- Limit switch
- Flasher operation
- Gear engagement
- Relays
- Tubes
- Lamps.

1.03 Make only those adjustments given in this section.

1.04 The 2A telephone answering set is equipped with a 152A plug-in type amplifier which may be one of three types. Main differences are as follows:

- (a) Sets with serial numbers preceded by letter A are equipped with an amplifier that is identified by the absence of a code marking.
- (b) Sets without the letter A preceding the serial number are equipped with an amplifier that is similar in appearance to the one described above except that the designation 152A is stamped in the upper left-hand corner of the printed circuit card as viewed from the front of the 2A set.

(c) Latest 2A sets (without letter A preceding serial number) are equipped with a third-style amplifier which is distinguished from the other two by a wider printed circuit card and the designation 152A stamped on the card near its center.

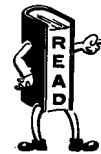

For replacement purposes amplifiers (b) and (c) may be used interchangeably; amplifier (a) is not interchangeable.

1.05 The 2A sets with letter A preceding serial number are equipped with both a START and a STOP button, have K2 lamps, and are equipped with an ON-OFF medallion light.

1.06 The 2A sets (earlier models) without letter A preceding serial number are equipped with an O operate button only, have GE 1847 lamps, and are not equipped with an ON-OFF light.

1.07 Latest 2A sets without letter A preceding serial number have same identifying features as earlier sets without letter A preceding serial number, except that ON-OFF medallion light is furnished.

1.08 **Rotation of the Drum:** Release latch and turn motor fan blades in counterclockwise direction with fingers. Take care not to bend fan blades. Latch may be released by pressing the plunger into the L1 solenoid manually, or electrically operating the L1 solenoid.



Do not attempt to rotate the drum by turning the flywheel as this may result in damage to the fiber gear of the motor drive unit.

1.09 In order to check the requirements contained in this section, it may be necessary to remove the 10A recorder from the telephone answering set as shown on the next page.

SECTION 514-124-301

Remove the three recorder mounting screws, bracket, and washers. Remove P1 and P4 plugs from associated jacks.

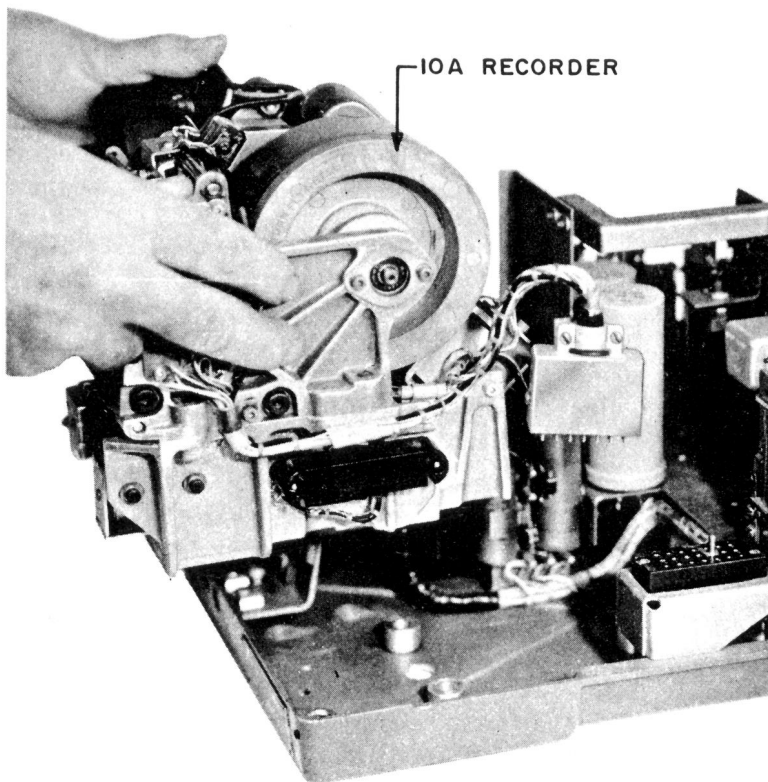
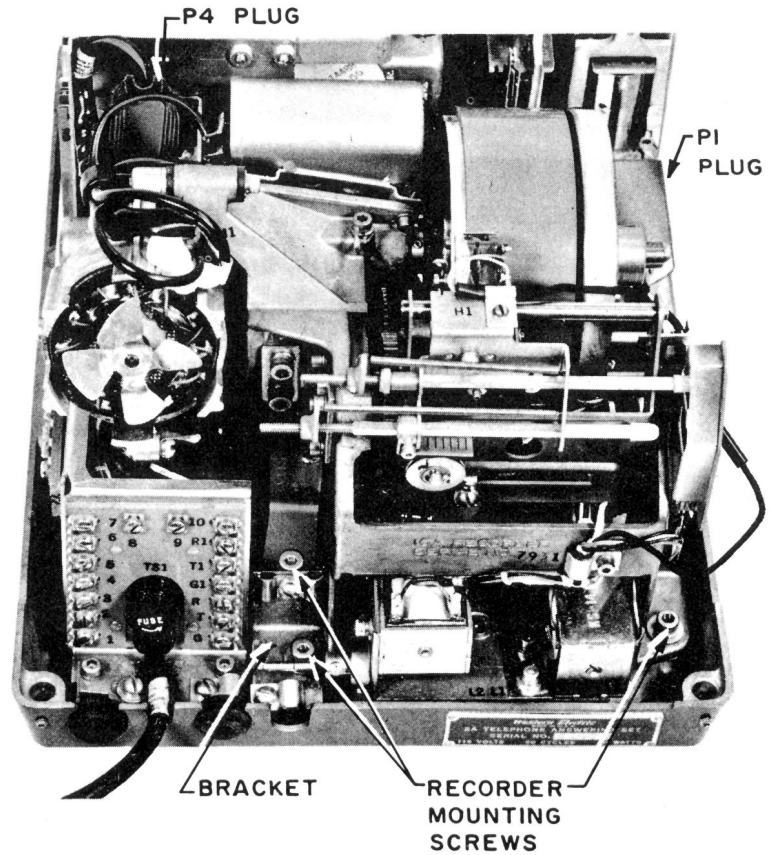

Taking care not to damage any adjacent wiring, lift the 10A recorder out of the answering set.

1.10 When it is necessary to electrically operate a solenoid to meet a requirement or make an adjustment, connect 48 volts dc across the terminals of the solenoid.

1.11 Tools, Gauges, and Materials

Tool	Description
Allen-type wrenches	0.050, 5/64, 1/16, 3/32, 1/8, and 5/32 inch
Open-end wrenches	3/8, 5/16, 1/4, 7/32, 13/32, and 1/2 inch
418A	Wrench
70D	Gauge, 50 - 0 - 50 grams
70J	Gauge, 0 - 150 grams
79B	Gauge, 0 - 1000 grams
81A	Test set
265C	Burnishing tool
374B and C	Burnishing blades
325B	Adjuster
328	Guide adjuster
363	Spring adjuster
415B	Spring adjuster
524A, B, and E	Spring adjusters
485A	Pliers
486A	Oil can
KS-2423	Cloth twill jean
KS-6320	Orange stick
KS-6909	Thickness gauges
KS-6938	Thickness gauges
KS-7860	Petroleum spirits
KS-16326, L1	Oil
KS-16328, L2	Cleaner
P-220366	Dental mirror
R-2966	No. 5 stiff artist's brush
Cleaning brush	Camel or sable hair
Trichloroethylene	
4/0 Emery polishing paper	Carborundum Co.

2.00 REQUIREMENTS**2.01 Lubrication**

- (a) The parts shown in the figures on Pages 4 and 5 shall be adequately lubricated with KS-16326, List 1 oil. When lubrication is necessary, the oil shall be applied as indicated.

- (1) (A) — Saturate the wicking. (Remove screw, using 1/8-inch Allen wrench.) *Note:* On some models the wicking is not provided.

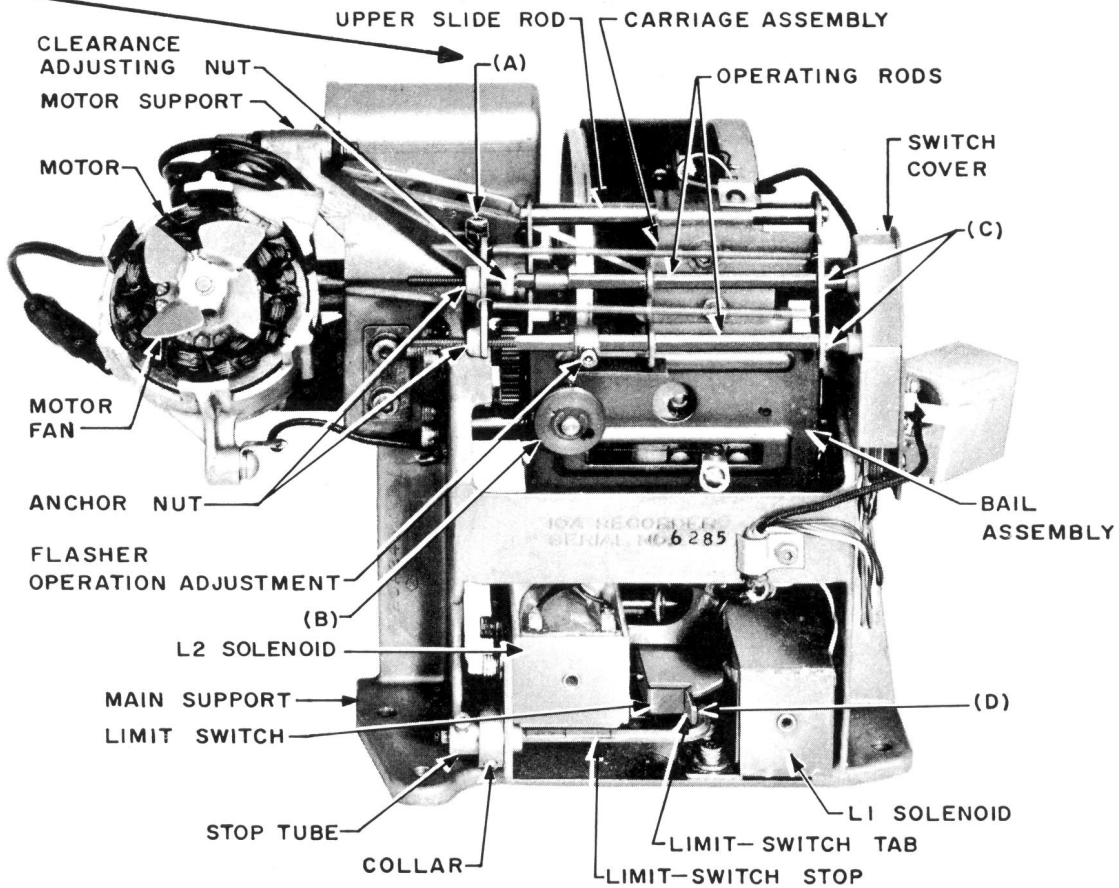

10A Recorder, Front View (Shown at End of Maximum Announcement Interval)

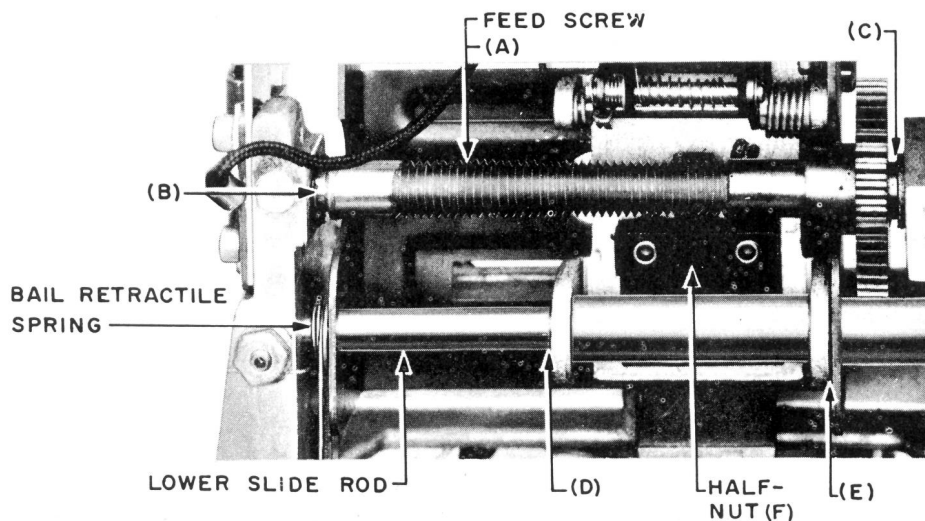

Half-Nut and Feed Screw Details

- (2) (A) — A film on threads of feed screw.
- (3) (B) and (C) — Two drops on exposed ends of feed screw bearings.
- (4) (D) and (E) — Two drops on carriage slide rod bearings.
- (5) Two drops on idler gear spindle.

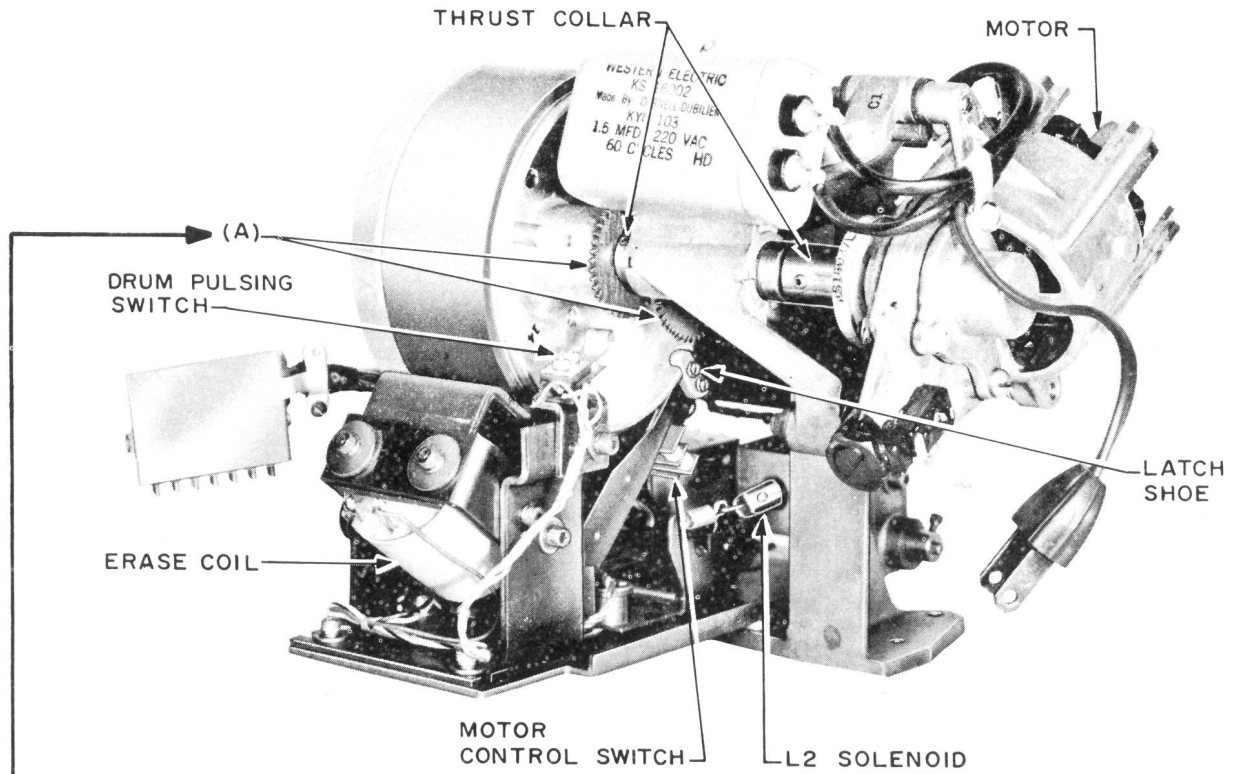

10A Recorder, Rear View

(6) (A) — A film on tooth surfaces of all gears.

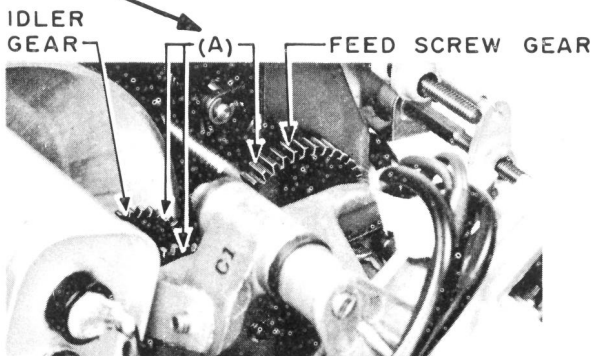

(7) (A) — Two drops on each thrust collar

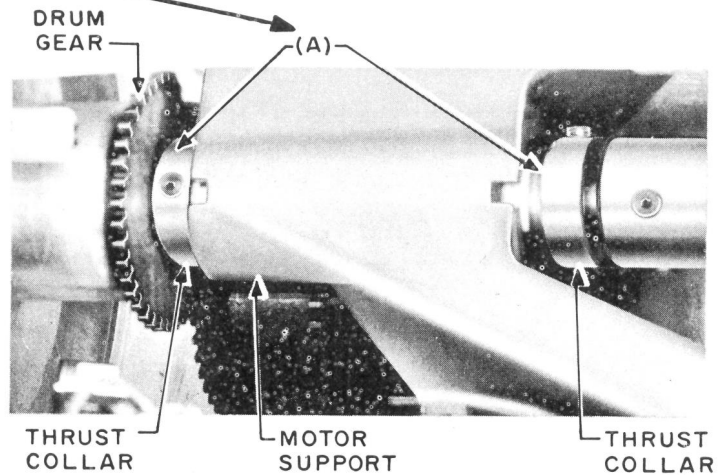

Drum Shaft

(b) *Recommended Lubrication Intervals:* It is recommended that the parts listed be lubricated annually. This interval may be extended if periodic inspections have indicated that local conditions are such as to ensure that the requirements will be met during the extended interval.

OPERATING CONTROLS

2.02 The function knob shall be positioned on the shaft so that white dot on knob is opposite white dot on panel, thus indicating check position when switch is operated to its center position.

2.03 The ON-OFF knob white dot shall be positioned equidistant between OFF designation in extreme counterclockwise position and ON designation in extreme clockwise position.

2.04 Operate button shall operate freely and shall be clear of panel surface by 1/64 inch.

ANNOUNCEMENT-BAIL CARRIAGE AND HEAD

2.05 With the L1 solenoid electrically operated, observe that clearance between bail assembly and bail stop shall be approximately 0.015 inch. Gauge by eye.

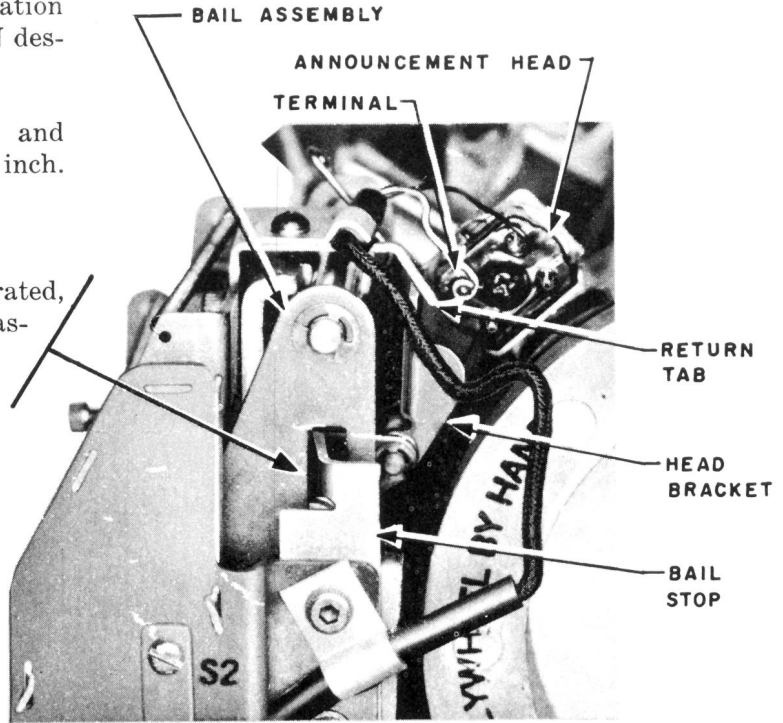

2.06 End play of bail shall be 0.012 inch maximum. Gauge by feel. Grasp bail and move from side to side in line with slide rod.

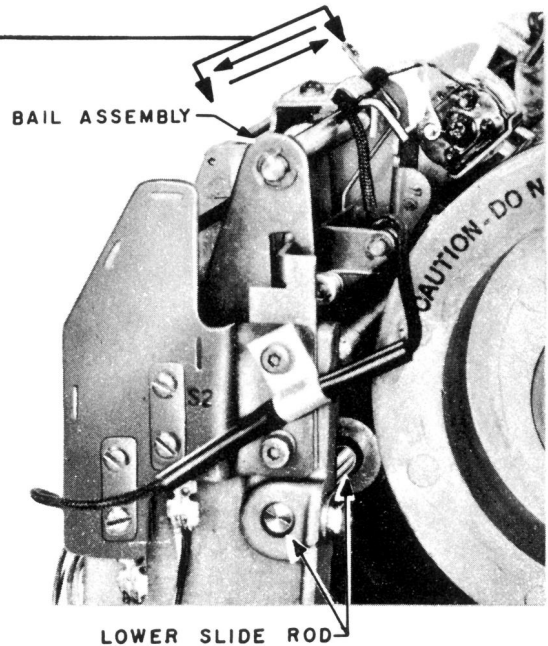



2.07 The bail assembly shall pivot freely on the lower slide rod. Push bail toward drum and release. Observe that bail assembly restores to its original position without bind or hesitation.

2.08 Carriage Feed Screw: [See figure at bottom of Page 4, Designation (A).] Screw shall turn freely in its bearings without perceptible end play. Gauge by eye and feel. To check this requirement, insert a finger behind the bail assembly and place it on feed screw. Attempt to rotate feed screw. Note that it turns freely within angle allowed by the backlash between gears and that there is no perceptible end play.

2.09 Carriage Half-Nut: [See figure at bottom of Page 4, Designation (F).] Operate L1 solenoid and move carriage toward right. Grasp carriage at point where pulley cord is attached and attempt to move carriage assembly. Take care not to force carriage assembly.

There shall be clearance between carriage half-nut and feed screw throughout return of carriage to zero position. To check this requirement, adjust limit switch for 60-second announcement interval. Operate L2 solenoid to release limit switch and slide switch to right until contact is made between limit switch tab and stop. Release L2 solenoid. Manually slide carriage assembly to right until carriage foot contacts limit switch button. Press bail assembly forward to its operated position. Release bail assembly and note any scraping noise during return of carriage.

2.10 Upper Slide Rod Clearance 

2.11 Tab Clearance 

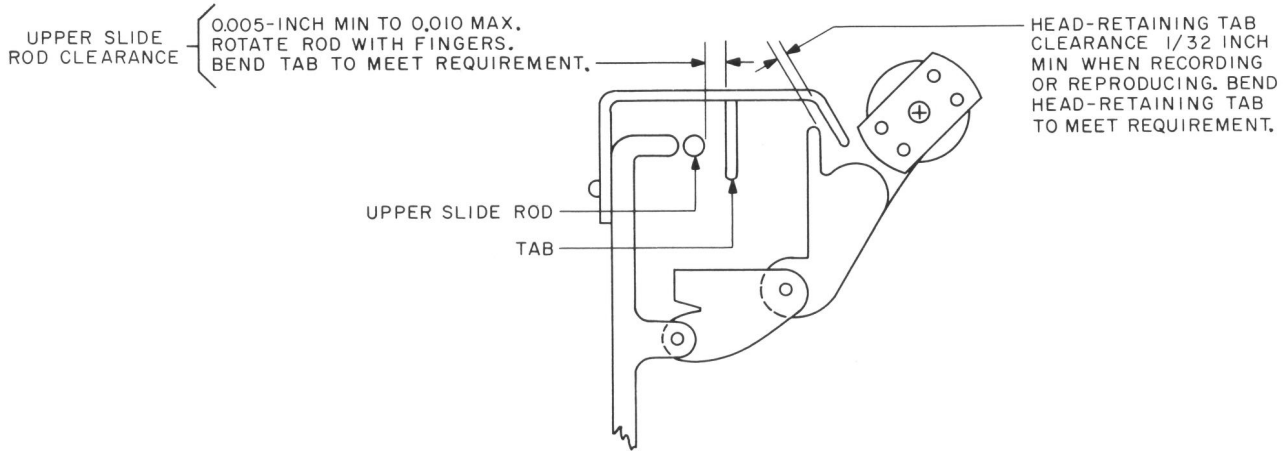

2.12 Recording Head Clearance

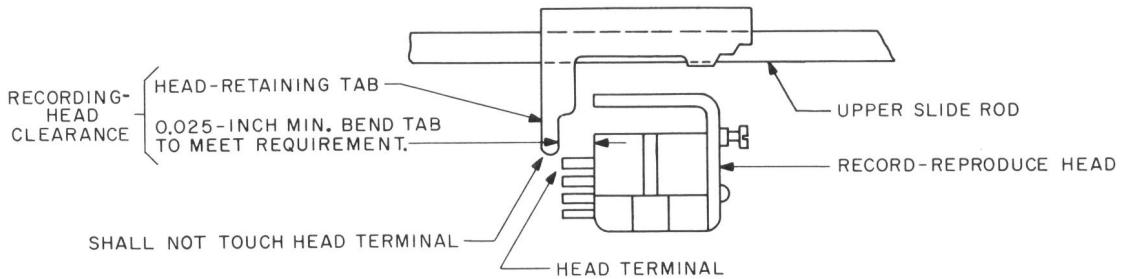

2.13 With the L1 solenoid nonoperated, the head return tab shall keep the head off drum.

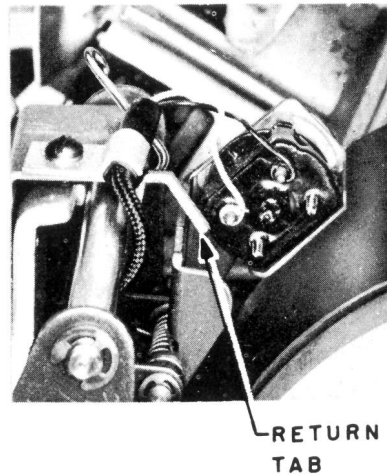

2.14 Head Pressure: With L1 operated, the head shall rest on drum with a pressure of 28 grams minimum, 43 grams maximum. Measure with 70D gauge as shown.

Adjust by changing the hole in which spring is engaged. With L1 de-energized, the tab must lift the recording head from the drum surface.

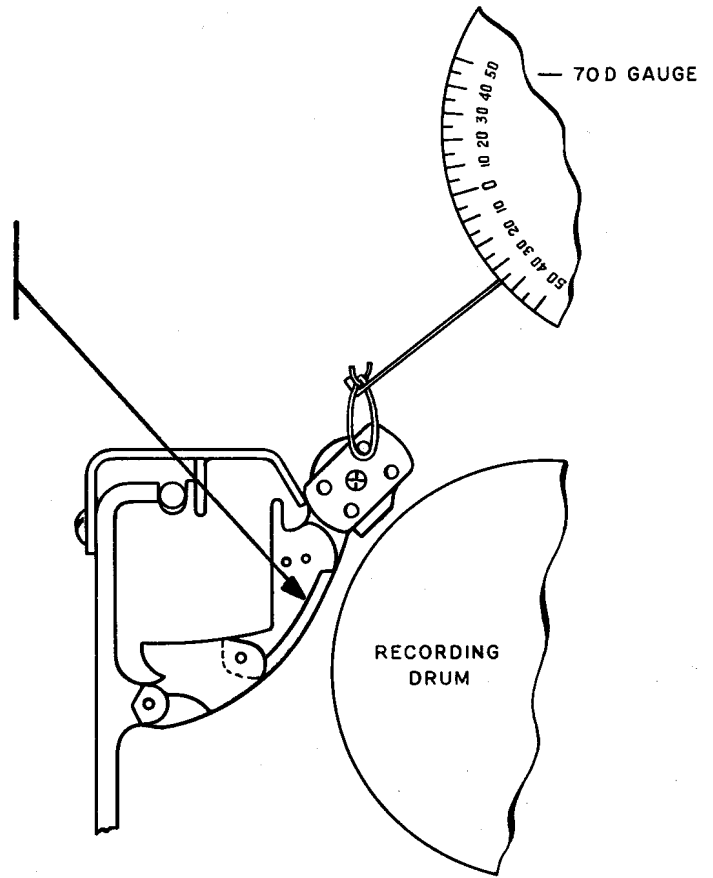

2.15 If output of answering set is below normal, check that gap of recording head is tangent to and in contact with surface of recording band.

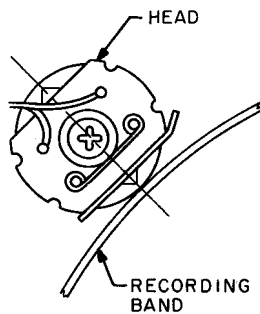

CORRECT ALIGNMENT

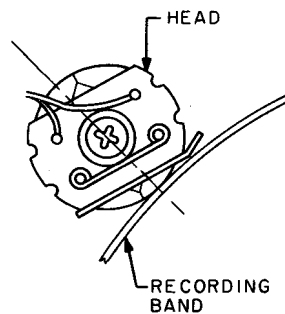

INCORRECT ALIGNMENT

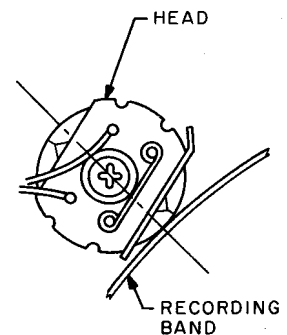

INCORRECT ALIGNMENT

2.16 Surface of head that contacts drum shall be minimum 7/32 inch and shall be free of scars and irregularities which may impair recording.

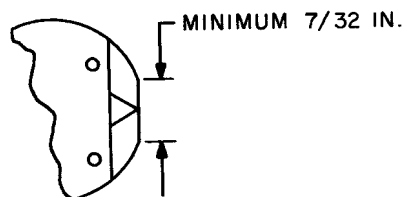

OPERATING RODS

2.17 The operating rods of the carriage assembly shall slide freely in the bracket. Gauge by eye and feel. Slide the rods within the range permitted by the stops and nylon tips.

2.18 *Engagement of Operating Rod and Associated Switch:* With bail assembly in operated position, operating rod shall engage operating spring below contacts and midway between center of spring and edge nearer to drum. Gauge by eye. To check this requirement, remove switch cover as follows: Straighten the tabs with No. 485A pliers so that tabs will pass through slots, taking care not to break tabs. Slide operating rods back toward motor and remove the switch cover. Manually slide carriage toward switch until operating rod contacts the contact spring. Operate L1 solenoid and note that requirement is met.

2.19 *To Measure Pressure on Timing and Flashing Switch Operating Rods,* place gauge on tension nuts with carriage in extreme left-hand position.

For Operation Sequence of Timing and Drum Pulsing Switches, the timing switch shall operate approximately one-half of a revolution after first operation of drum pulsing switch. Use No. 81A test set. To check operation sequence of switches, start with latch engaged in drum notch. Operate L1 solenoid and connect No. 81A test set across terminals of timing switch. Rotate drum manually and note that timing switch contacts are closed approximately midway between first and second operation of drum pulsing switch.

Note: The carriage assembly must return freely and positively from any position throughout its travel. The half-nut must not scrape on the feed screw.

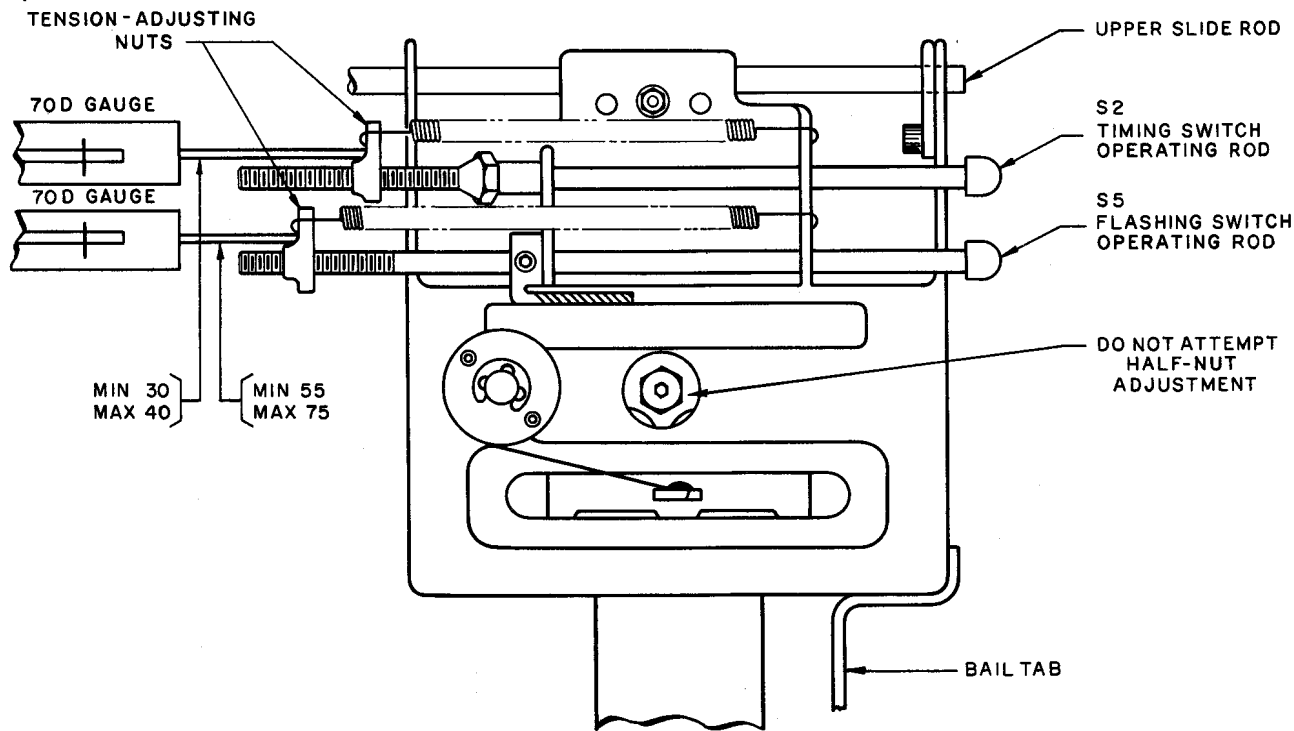

When contact alignment timing and flashing switch is operated, the point of contact shall fall wholly within boundary of opposing contact disc.

Contact separation of switch un-operated shall be 0.006 inch minimum, 0.020 inch maximum. Gauge by eye.

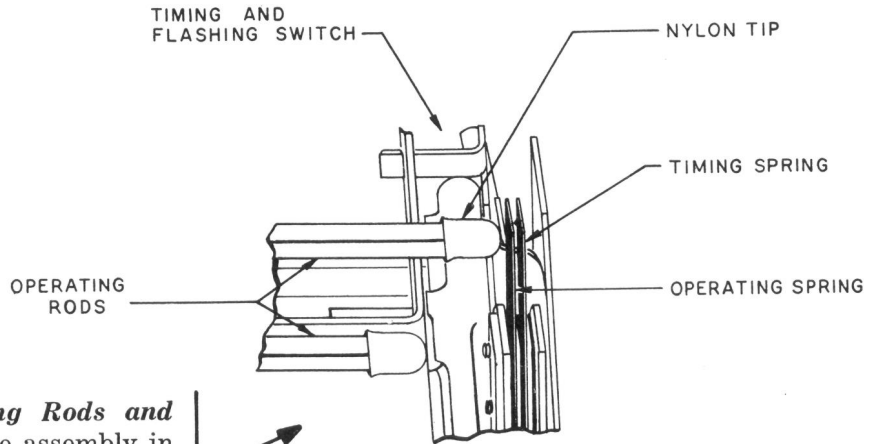

2.20 Clearance Between Operating Rods and Timing Switch: With carriage assembly in zero position, there shall be a separation of approximately 0.010 inch between operating spring of timing switch (S2) and nylon tip of its associated operating rod. Gauge by eye.

DRUM CLUTCH PRESSURE

2.21 Index set to ANNOUNCEMENT CHECK. Depress START button.

- Disengage drum latch manually. Insert KS-6320 orange stick into opening below drum assembly.
- Apply pressure with 79B gauge to halt rotation of drum — 225 grams minimum, 325 grams maximum.
- Slowly decrease pressure and note when drum starts to rotate.

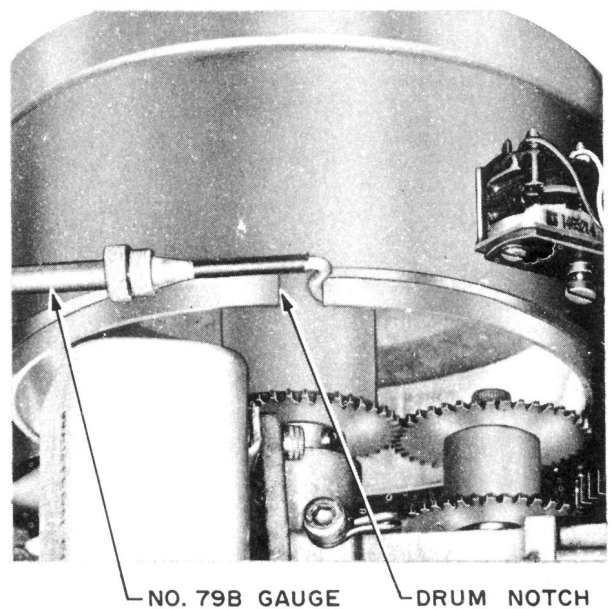
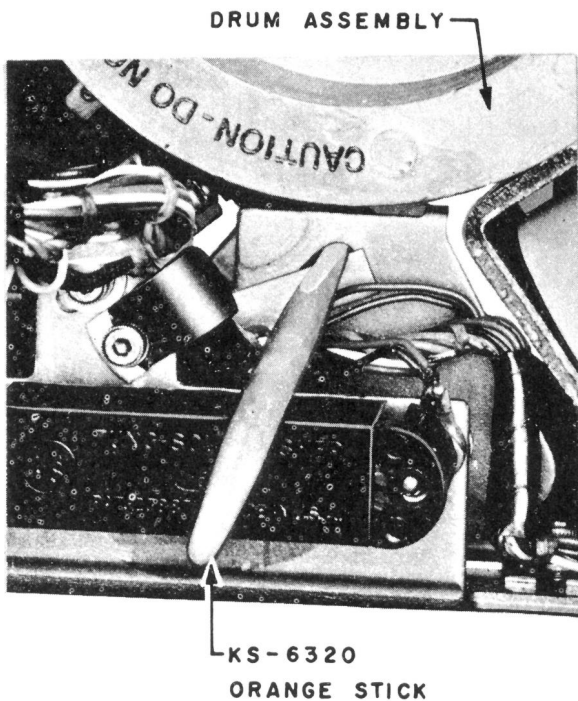

ERASE COIL ASSEMBLY

2.22 The erase coil assembly shall be so positioned that pole-piece gap is centered across width of recording band. Gauge by eye.

There shall be a clearance of 0.010 inch minimum, 0.040 inch maximum between erase coil pole pieces and drum throughout complete revolution of drum. Check this requirement at four positions, each one-fourth of a revolution apart. Use KS-6909 and KS-6938 gauges.

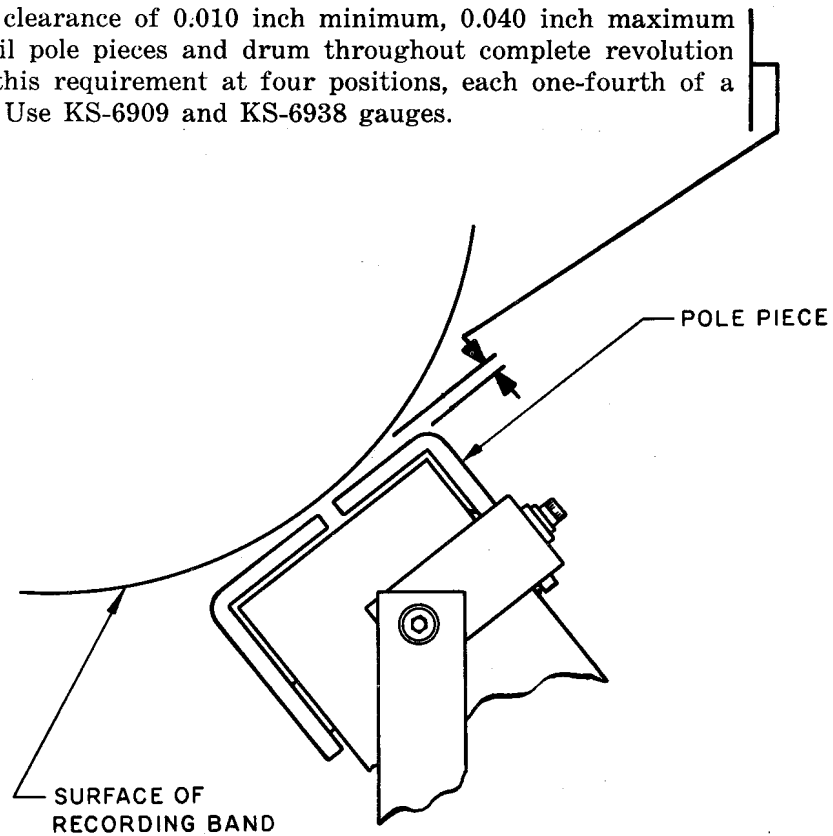

DRUM LATCH AND MOTOR CONTROL SWITCH

2.23 With latch resting on metal surface of drum, there shall be clearance between latch and side of band. Latch shall not extend over edge of drum. Gauge by eye.

With latch in notch of drum, it shall clear side of band and side of notch adjacent to band.

With set in ANNOUNCEMENT CHECK position, depress and hold START button operated, and observe that:

- Drum latch clears metal surface of drum, 0.015 inch minimum.
- Switch S3 operates.

Release START button.

- Latch shall drop into notch when it is opposite notch.

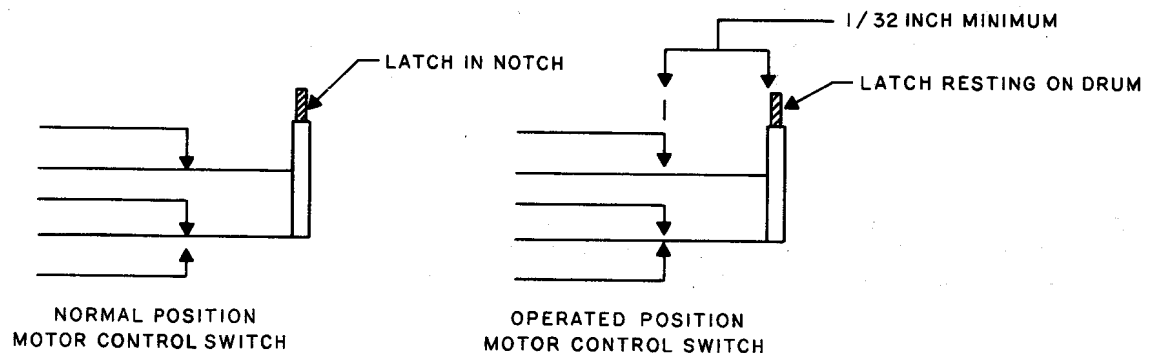
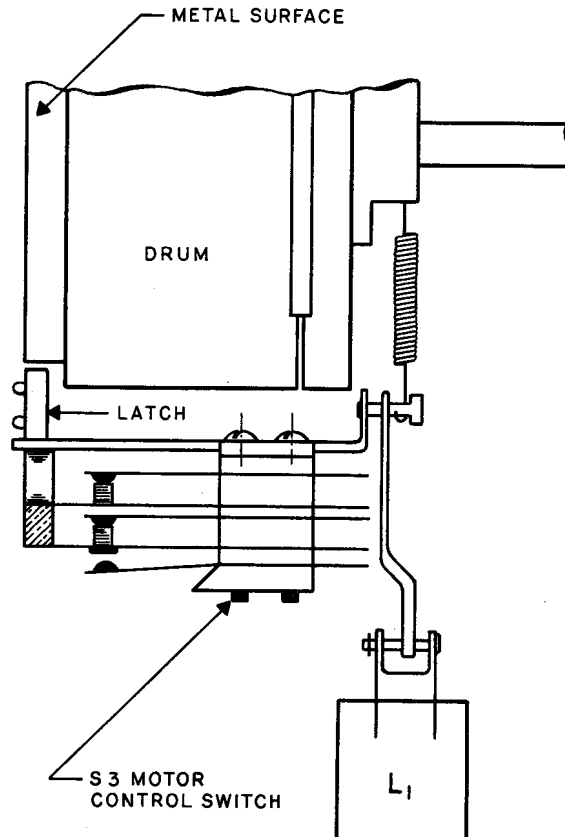

With L1 de-energized and latch shoe riding on drum of motor control switch S3, the lowest set of contacts (normally open) shall be closed, 0.010 inch minimum. These contacts must be open when latch is in drum notch.

Separation between all normally closed contacts with switch operated and between all normally open contacts with switch unoperated shall be 0.006 inch minimum. Gauge by eye.

2.24 Drum Pulsing Switch (S1):

No part of drum pulsing switch shall rub against recording drum except as intended between contact spring and insulated pin.

S1 contacts shall have follow of 0.010 inch minimum. Gap when open shall be 0.006 inch minimum. Gauge by eye.

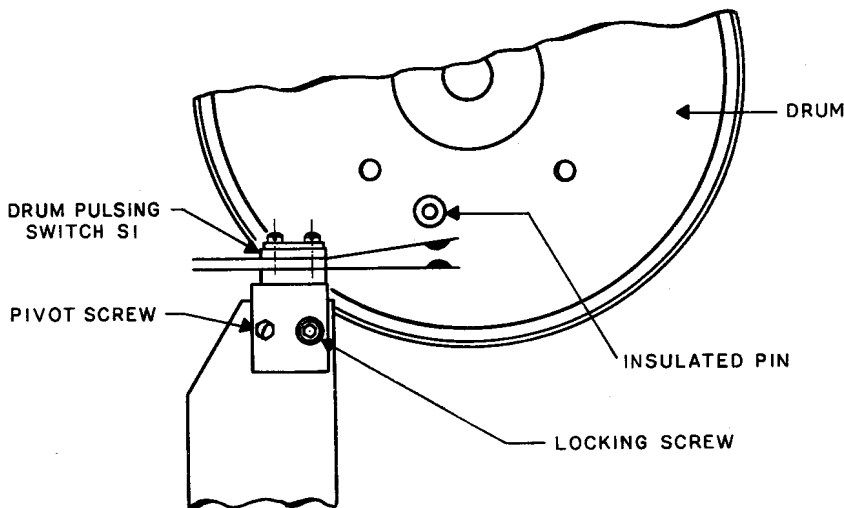

LIMIT SWITCH

2.25 Limit Switch Movement: (See figure at top of Page 4.) Limit switch shall return freely to zero position when L2 solenoid is electrically operated. Gauge by eye.

To check, electrically operate L2 solenoid and, with a KS-6320 orange stick, move limit switch to right. Release limit switch and observe that switch returns to zero position without hesitation. Check this requirement several times, moving close to zero position at least once.

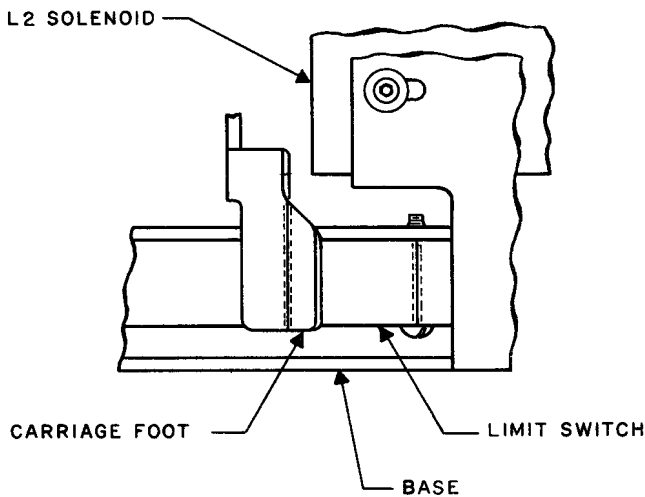

2.26 With L1 solenoid operated, there shall be a clearance of 1/32 inch minimum between carriage foot and frame of L2 solenoid. Gauge by eye.

2.27 With carriage and limit switch assembly in zero position, carriage foot shall coincide approximately with periphery of limit-switch button. Use P-220366 dental mirror. Gauge by eye.

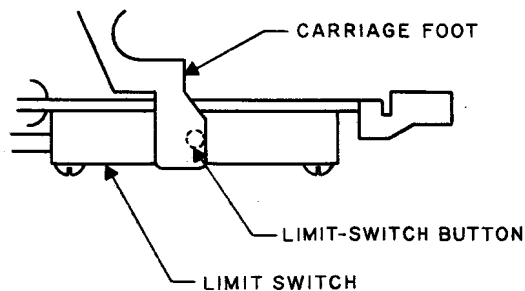

FLASHER OPERATION

2.28 The flasher switch or limit switch is to warn the set operator that the end of the recording interval is approaching. This is done by causing a lamp to flash upon operation of flasher switch. The interval of time before the lamp starts to flash is determined by the flasher indicator setting.

GEAR ENGAGEMENT

2.29 All gears shall engage to a depth of:

- Minimum — 1/32 inch
- Maximum — shall not bottom or bind.

To check minimum, use P-220366 dental mirror. Gauge by eye. To check maximum, gauge by feel.

2.30 Carriage feed screw gear and its associated gear shall be so aligned that minimum one-half thickness of thinner gear is in engagement with thicker gear. Gauge by eye.

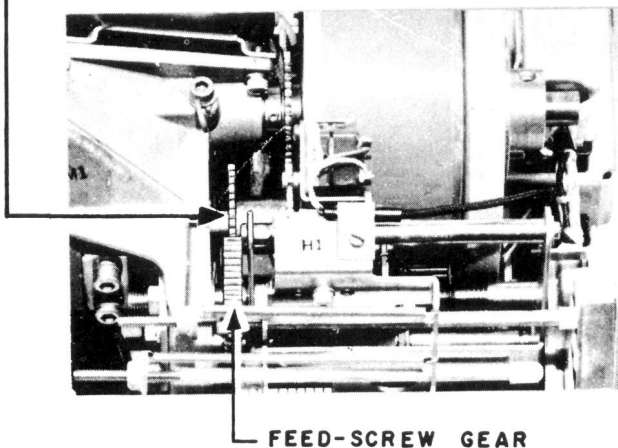
**RELAYS**

2.31 Relay contact springs shall meet the following requirements:

- Contact gap 0.005 inch minimum when open.
- Contact pressure 15 grams minimum when closed.
- Contact follow 0.010 inch minimum.
- Contacts shall be aligned so that point of one contact falls wholly within the area of the opposing contacts during the period that the contacts are made.

TUBES

2.32 Whenever testing indicates tubes require replacing, use only known good tubes as replacements, and retest set. A set of known good tubes should be kept on hand for use in locating suspected defective tubes. Defective tubes should be disposed of immediately to prevent possible reuse.

LAMPS

2.33 On sets with letter A preceding serial number, use K2 lamps. (Remove enough of white plastic band so that maximum light will be directed on panel.) On other sets, use 1847 lamps.

SECTION 514-124-301

3.00 ADJUSTMENTS

3.01 (Reqt 2.01) Lubrication — adjustments not applicable.

OPERATING CONTROLS

3.02 (Reqt 2.02) With cover fastened to base, the function selector knob and OFF-ON knob shall have complete rotational freedom as gauged by eye and feel. If binding is indicated, replace set.

3.03 (Reqt 2.03) }
3.04 (Reqt 2.04) } — Reposition as required.

ANNOUNCEMENT-BAIL CARRIAGE AND HEAD

3.05 (Reqt 2.05) If the clearance between the bail stop and bail assembly in the operated position is unsatisfactory, adjust the position of stop as required, using 325B adjuster.

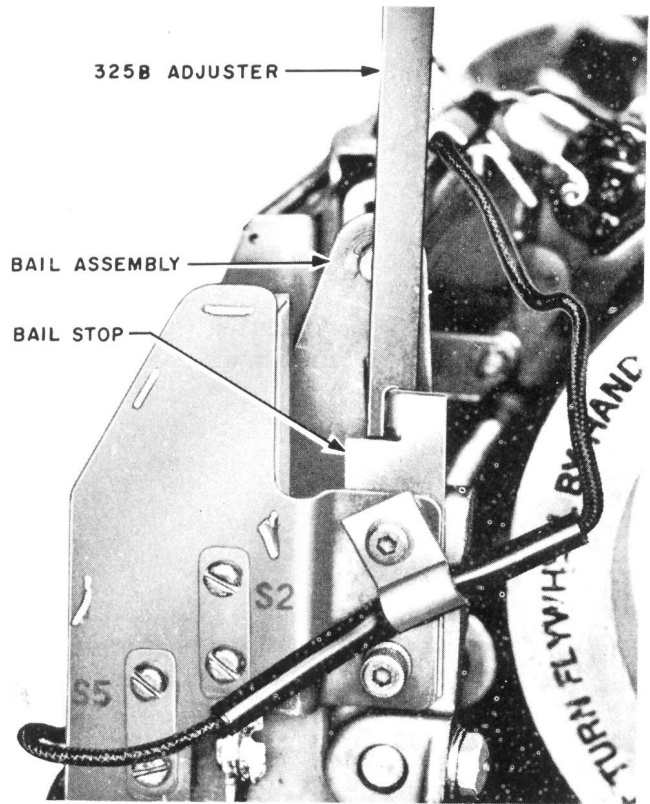

3.06 (Reqt 2.06) }
3.07 (Reqt 2.07) }
3.08 (Reqt 2.08) } — Field adjustment
3.09 (Reqt 2.09) } not recommended —
replace set.

3.10 (Reqt 2.10)

Method of bending tab for maximum slide rod clearance.

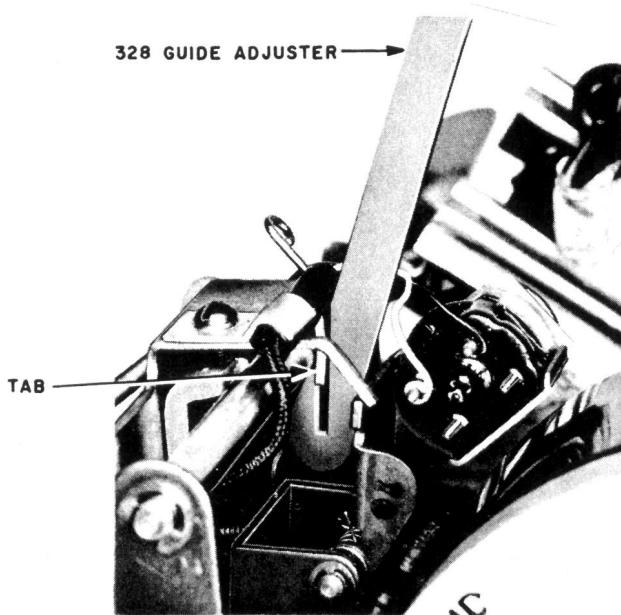

Method of bending tab for minimum slide rod clearance.

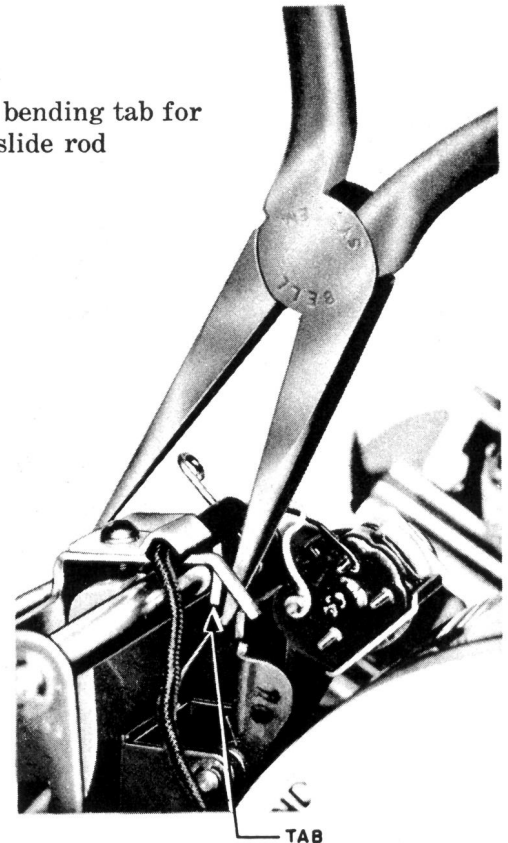

3.11 (Reqt 2.11)

3.12 (Reqt 2.12)

3.13 (Reqt 2.13)

Failure to meet these requirements may be corrected by adjusting the tab as required, using 325B adjuster.

3.14 (Reqt 2.14) Requirement and adjustment shown in 2.14.

3.15 (Reqt 2.15) Field adjustment not recommended — replace set.

3.16 (Reqt 2.16) Place a narrow strip of Carborundum No. 4/0 emery polishing paper between head and drum. Apply light pressure to head and pull strip of polishing paper past head until strip is withdrawn so surface of head that ordinarily contacts drum is polished by paper. Repeat this operation ten times.

Re-examine gap area of head, using dental mirror. Lap again if scars and irregularities are still pronounced enough to interfere with recording. If condition does not improve or if face of head is worn to length of 7/32 inch or more, replace set.

OPERATING RODS

3.17 (Reqt 2.17)

3.18 (Reqt 2.18)

(a) If engagement requirements cannot be met at both switches by approximately the same amount, proceed as follows:

- Reposition switch mounting plate.
- Loosen the two mounting screws.
- Shift mounting plate as required, taking care not to disturb position of bail stop.

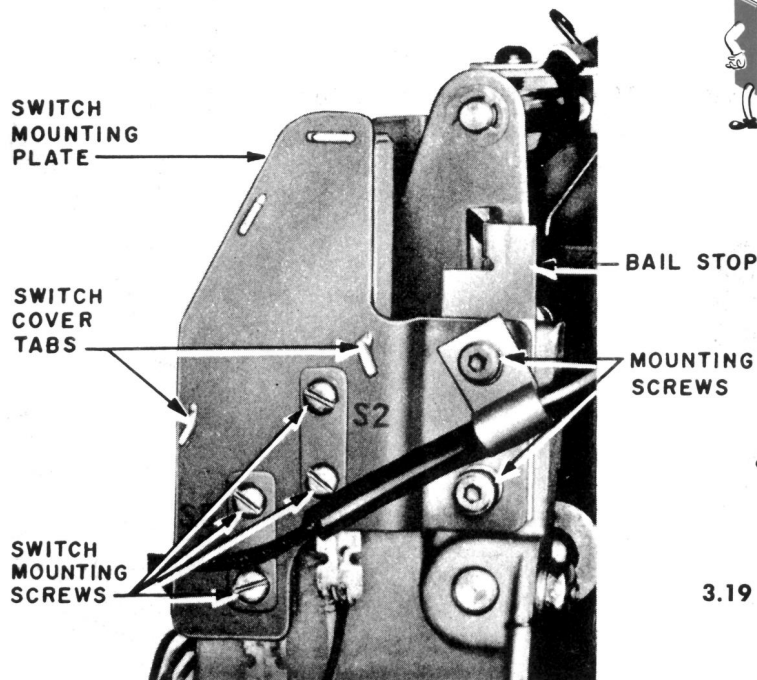

Take care not to change relationship of the contacts.

- Tighten mounting screws securely and check that requirement is met.
 - Check position of bail stop as covered in Requirement 2.05.
- (b) If failure to meet the engagement requirement is present at only one switch, proceed as follows:
- Reposition the individual switch assembly.
 - Loosen the two switch mounting screws.
 - Shift switch assembly as required.



Take care not to change relationship of the contacts.

- Tighten mounting screws securely and check that switch position meets Requirement 2.18.
- (c) Failure to meet contact alignment requirement may be corrected by positioning the stationary spring as follows:
- Loosen the switch mounting screw.
 - Shift stationary spring as required.

- Tighten mounting screws securely and check that switch position meets Requirement 2.18.

3.19 (Req't 2.19) The following adjustments may be made:

- **Operating Rod Spring Tension:** Unhook end of spring at fault from tension-adjusting nut. Turn nut as required to obtain proper tension. Position nut so that ear of nut is uppermost and long dimension is vertical. Hook spring back on nut and check that requirement is met.
- **Carriage Assembly:** Refer to 3.10. If upper slide rod clearance is met and carriage assembly still does not return freely, check lower slide rod. Disengage carriage half-nut from feed screw and slide carriage back and forth to check if there is binding. If binding is present, clean lower slide rod with KS-7860 petroleum spirits. If trouble still persists, replace set.
- **Operating Sequence of Timing and Drum Pulsing Switches:** To obtain required contact separation, adjust stationary spring with 415B adjuster. Place adjuster on spring as close to base as possible. Adjust spring to right or left as required.

If timing switch contacts do not close at approximately one-half revolution after closure of drum pulsing switch contacts, proceed as follows:

- Check separation between contacts of timing switch.

- If closure of timing switch is late, reduce separation toward minimum by adjusting stationary spring.
- If closure is early, increase separation by adjusting stationary spring.

If a satisfactory adjustment cannot be met, an adjustment of clearance between operating rod and operating spring will be necessary; proceed as covered in 3.20.

With half-nut and feed screw engaged, the operating rod button must contact the S2 spring approximately 3/32 inch below the top of spring and halfway between centerline of spring and edge toward drum as gauged by eye.

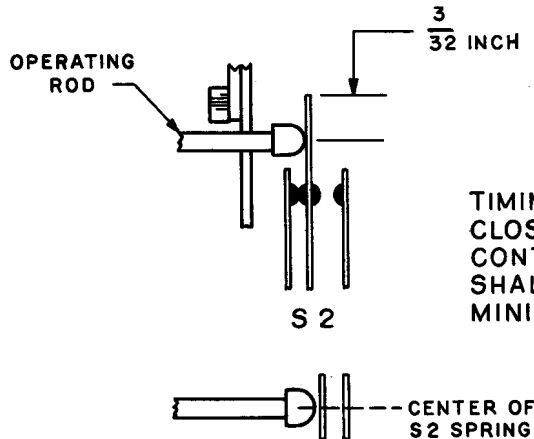

TIMING SWITCH NORMALLY CLOSED
CONTACT PRESSURE SHALL BE 15 GRAMS MINIMUM.

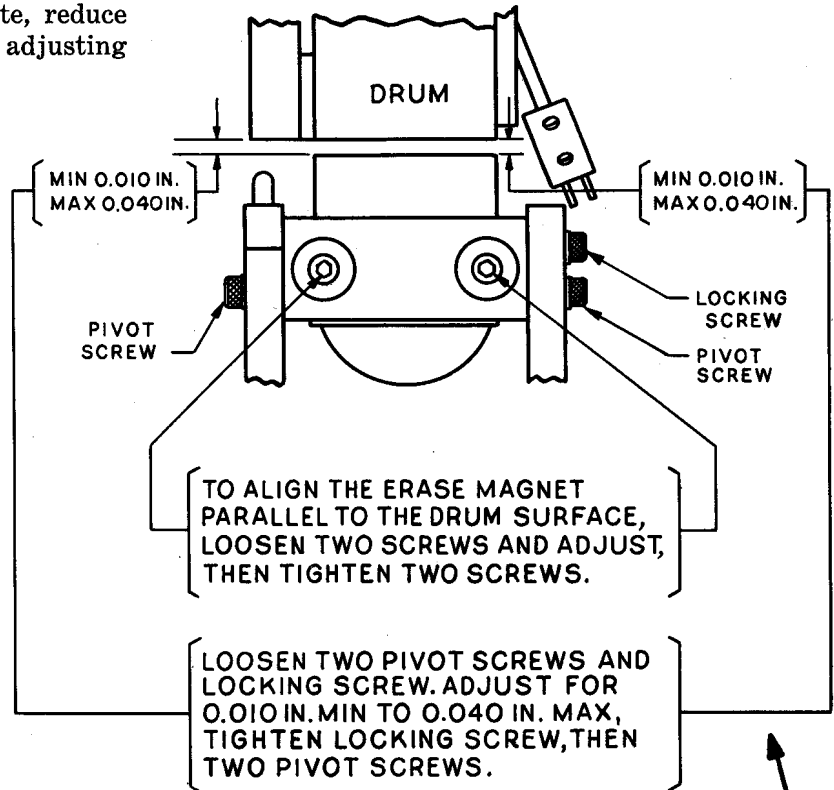

ERASE COIL ASSEMBLY
3.22 (Reqt 2.22)

To adjust, loosen screws holding spring pile-up, then position spring. Tighten mounting screws securely and check that switch position meets Requirement 2.18.

3.20 (Reqt 2.20) If clearance is not satisfactory, adjust by turning adjusting nut adjacent to brass spacer as required. Use 418A wrench. Check that operation sequence of timing and drum pulsing switches is met, as in Requirement 2.19.

DRUM CLUTCH PRESSURE

3.21 (Reqt 2.21) Field adjustment not recommended — replace set.

DRUM LATCH AND MOTOR CONTROL SWITCH

3.23 (Reqt 2.23) Field adjustment not recommended — replace set.

3.24 (Reqt 2.24) Loosen locking screw and position, then tighten locking screw.

LIMIT SWITCH

3.25 (Reqt 2.25)

3.26 (Reqt 2.26)

3.27 (Reqt. 2.27)

Field adjustment not recommended — replace set.

FLASHER OPERATION

3.28 (Reqt 2.28)

Announcement Length Adjustment:

With carriage in zero position, operate L2 solenoid so that limit switch moves to zero position.

Loosen stop setscrew. Position stop so that mark representing desired maximum announcement interval is flush with left face of tube. Tighten setscrew to secure adjustment.

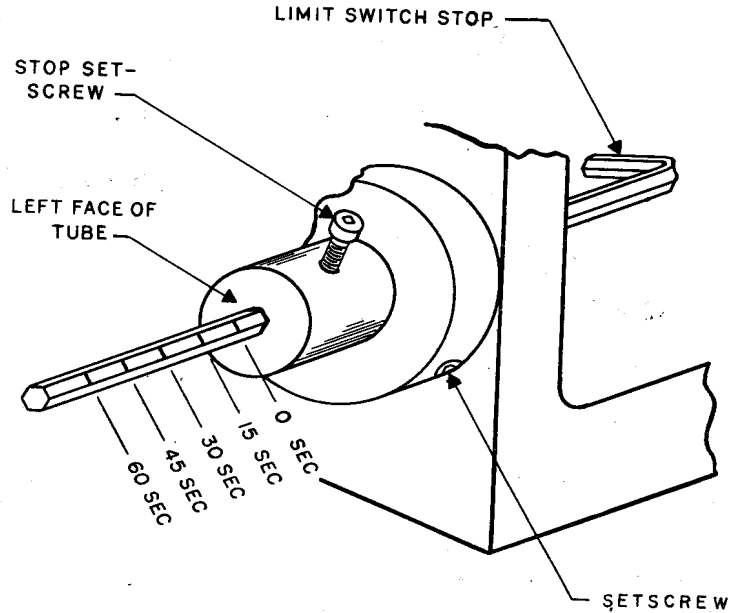

Flasher Indicator Adjustment:

Operate L2 solenoid and manually slide carriage toward right until limit switch tab engages limit switch stop. Operate L1 solenoid to hold carriage in this position and loosen setscrew in indicator assembly. Tighten setscrew to secure setting.

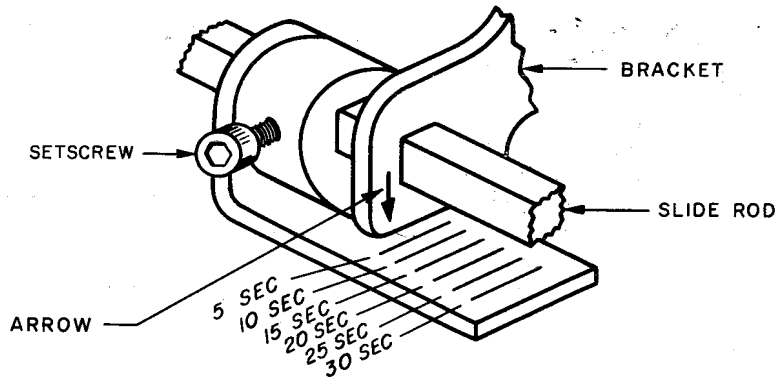

GEAR ENGAGEMENT

3.29 (Reqt 2.29) } Field adjustment
 3.30 (Reqt 2.30) } not recommended —
 replace set.

RELAYS

3.31 (Reqt 2.31) Refer to sections entitled Cleaning and Reconditioning Relay Contacts. Individual relay electrical and mechanical requirements can be found in the circuit requirement tables.

TUBES

- 3.32 (Reqt 2.32)**
- V1 — CK512AX amplifier
 - V2 — CK512AX amplifier
 - V3 — 3V4 amplifier
 - V4 — 3V4 oscillator.

LAMPS

3.33 (Reqt 2.33) Refer to Requirement.